

_OFFER VALIDITY PERIOD:01.04. – 24.05.2024

Xill-tec[®] – Universal eXcellence
for milling applications



YOUR SAVINGS
50%

- Can be used universally with all ISO materials
- Comprehensive range: With corner radii, protective chamfer, plain shank and Weldon shank
- Long tool life due to high-performance grade WK40EA
- Regrindable in all Walter Reconditioning Centers with performance guarantee

Xill-tec® – universal milling with eXcellence.

THE TOOL

- Xill-tec® MC230 and MC233 Advance milling cutters with chip separators
- Diameter range: 2–25 mm
- z=2–8
- Cutting edge length (Lc): 1×Dc to 5×Dc
- New geometry with variable helix; differential pitch tailored to number of teeth (z)

THE GRADE

- Universal, tough milling grade WK40TF: With TiAlN coating

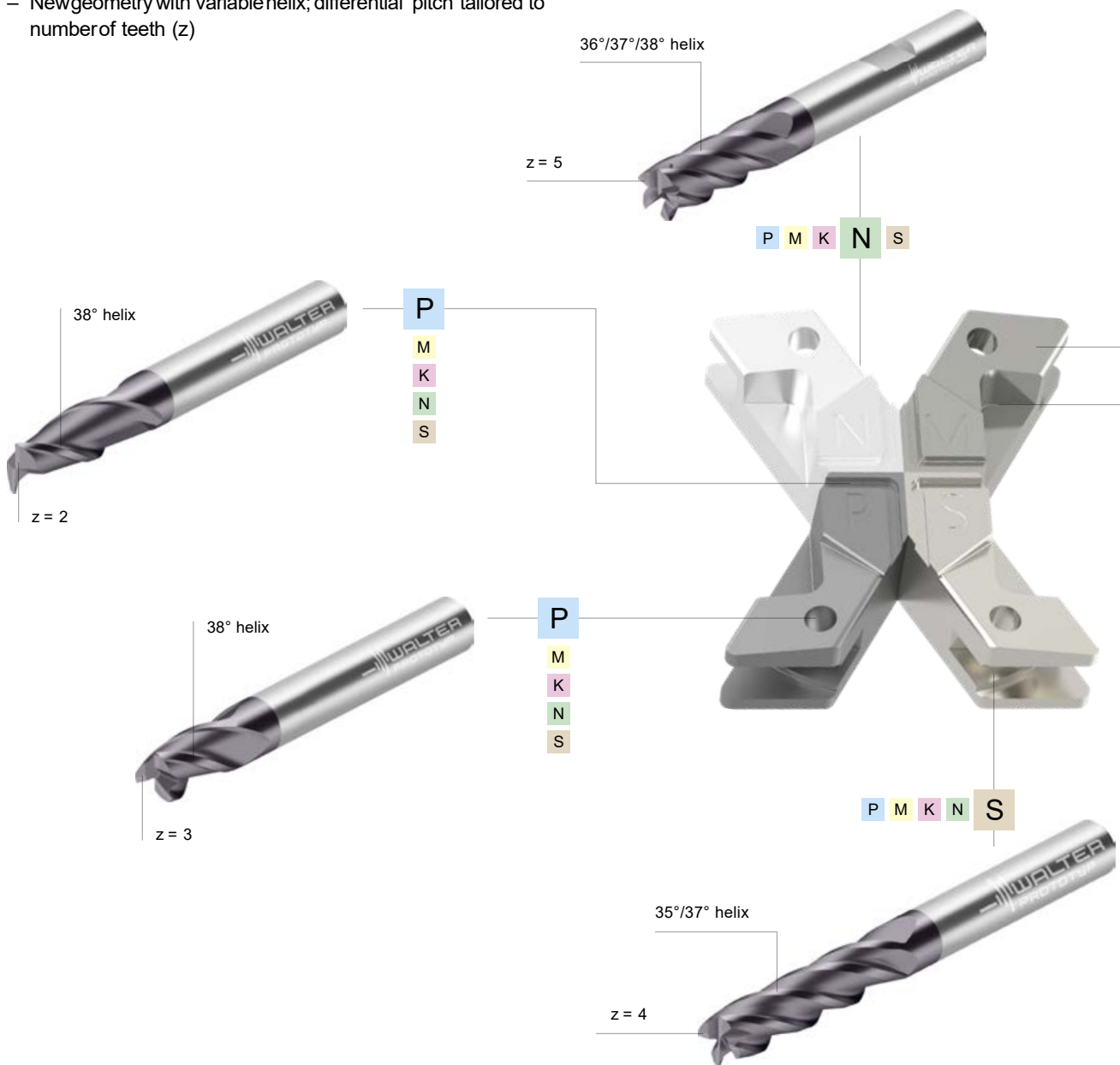

THE APPLICATION

The top choice for universal roughing and finishing

- For ISOmaterials P, M, K, N and S
- z2–3: Slot milling, keyslot milling and profile milling
- z4: Slot milling and helical milling, plunging, ramping
- z5: Roughing/finishing tool
- z6–8: Dynamicmilling and finishing
- Areas of use: Generalmechanical engineering, mould and die making, sub-supplier for the aerospaceindustry, medical technology, energy and automotive industries

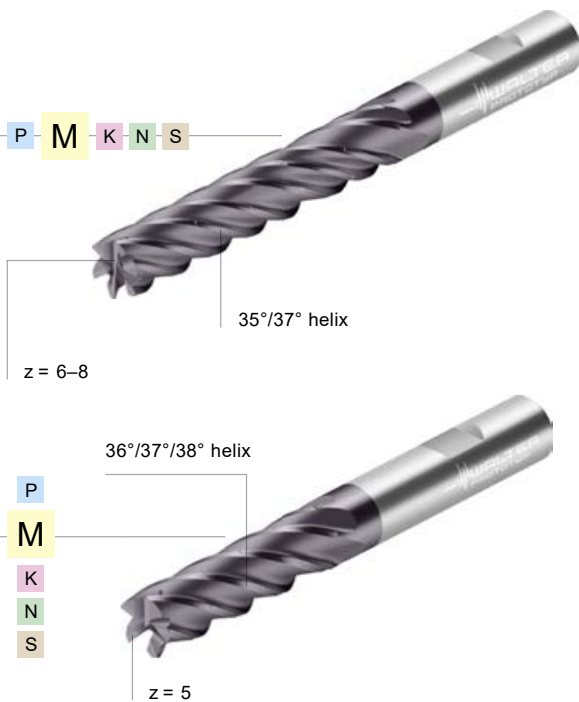

Xill-tec® MC233 Advance
solid carbide milling cutters

Fig.: Xill-tec® MC233 Advance
WK40TF

APPLICATION EXAMPLE

Module hinge

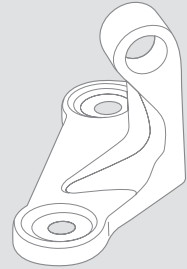

Material:	GJS400-18 / Material no.: 5.3105 [160 HB]	
Tool:	MC233-25.0W8XL-WK40TF	
Cutting data	Competitor	Xill-tec® MC233 Advance
D _c (mm)	25	25
z	8	8
v _c (m/min)	154	154
f _z (mm)	0.28	0.28
v _f (mm/min)	4390	4390
a _e (mm)	0.33	0.5
a _p (mm)	125	125
Q (cm ³ /min)	183	257
T _e (min)	6	4

Comparison: Tool life quantity

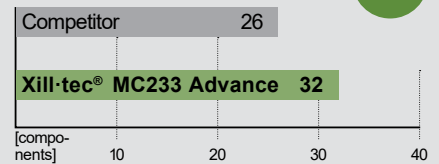

BENEFITS FOR YOU

- Universal application with all ISOmaterials using all common milling strategies
- Optimal operational smoothness and tool life increase due to special geometry

Solid carbide shoulder/slot milling cutters

MC230 Advance mm

Xill-tec®

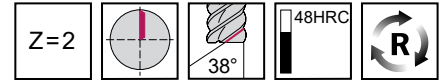
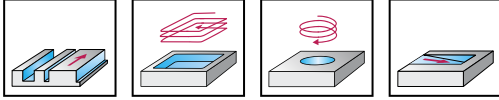

	P	M	K	N	S	H	O
WK40TF	CC	C	C	C	C		

Designation	D _c	R	L _c	Z	SAP No.
MC230-02.0A2B-BOW-TF	2		6.0	2	8361591
MC230-02.5A2B-BOW-TF	2.5		7.0	2	8361592
MC230-03.0A2B-BOW-TF	3		7.0	2	8361593
MC230-03.5A2B-BOW-TF	3.5		7.0	2	8361594
MC230-04.0A2B-BOW-TF	4		8.0	2	8361595
MC230-04.5A2B-BOW-TF	4.5		8.0	2	8361596
MC230-05.0A2B-BOW-TF	5		10.0	2	8361597
MC230-06.0A2B-BOW-TF	6		10.0	2	8361598
MC230-07.0A2B-BOW-TF	7		13.0	2	8361599
MC230-08.0A2B-BOW-TF	8		16.0	2	8361610
MC230-09.0A2B-BOW-TF	9		16.0	2	8361611
MC230-10.0A2B-BOW-TF	10		19.0	2	8361612
MC230-11.0A2B-BOW-TF	11		22.0	2	8361613
MC230-12.0A2B-BOW-TF	12		22.0	2	8361614
MC230-14.0A2B-BOW-TF	14		22.0	2	8361615
MC230-16.0A2B-BOW-TF	16		26.0	2	8361616
MC230-18.0A2B-BOW-TF	18		26.0	2	8361617
MC230-20.0A2B-BOW-TF	20		32.0	2	8361618

Sender

Company

Name

Buildingno./street name

Town/postcode

Date

Signature

Use this form to fax your order now.

In collaboration with:



walter-tools.com

Planned start date is 01.04.2024. Offer validity period: Eight weeks or while stocks last. Please allow three to five working days for delivery. Products on special offer cannot be exchanged. Illustrations show similar products. Subject to change without notice. Recommended sales price.

Solid carbide shoulder/slot milling cutters

MC230 Advance mm

Xill-tec®

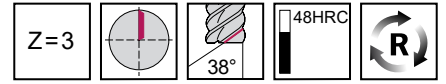
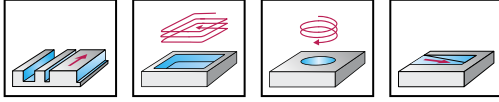

	P	M	K	N	S	H	O
WK40TF	CC	C	C	C	C		

Designation	D _c	R	L _c	Z	SAP No.
MC230-02.0A3S-BOW-TF	2		3.0	3	8361676
MC230-03.0A3S-BOW-TF	3		4.0	3	8361677
MC230-04.0A3S-BOW-TF	4		5.0	3	8361678
MC230-05.0A3S-BOW-TF	5		6.0	3	8361679
MC230-06.0A3S-BOW-TF	6		7.0	3	8361680
MC230-08.0A3S-BOW-TF	8		9.0	3	8361681
MC230-10.0A3S-BOW-TF	10		11.0	3	8361675
MC230-12.0A3S-BOW-TF	12		13.0	3	8361682

Designation	D _c	R	L _c	Z	SAP No.
MC230-01.0W3B-BOW-TF	1		3.0	3	8361729
MC230-01.5W3B-BOW-TF	1.5		3.0	3	8361730
MC230-02.0W3B-BOW-TF	2		6.0	3	8361728
MC230-02.5W3B-BOW-TF	2.5		7.0	3	8361731
MC230-03.0W3B-BOW-TF	3		7.0	3	8361732
MC230-03.5W3B-BOW-TF	3.5		7.0	3	8361733
MC230-04.0W3B-BOW-TF	4		8.0	3	8361734
MC230-04.5W3B-BOW-TF	4.5		8.0	3	8361735
MC230-05.0W3B-BOW-TF	5		10.0	3	8361736
MC230-05.5W3B-BOW-TF	5.5		10.0	3	8361737
MC230-06.0W3B-BOW-TF	6		10.0	3	8361738
MC230-08.0W3B-BOW-TF	8		16.0	3	8361739
MC230-09.0W3B-BOW-TF	9		16.0	3	8361740
MC230-10.0W3B-BOW-TF	10		19.0	3	8361741
MC230-12.0W3B-BOW-TF	12		22.0	3	8361742
MC230-14.0W3B-BOW-TF	14		22.0	3	8361743
MC230-16.0W3B-BOW-TF	16		26.0	3	8361744
MC230-20.0W3B-BOW-TF	20		32.0	3	8361745

Designation	D _c	R	L _c	Z	SAP No.
MC230-02.0A3B-BOW-TF	2		6.0	3	8361619
MC230-02.5A3B-BOW-TF	2.5		7.0	3	8361620
MC230-03.0A3B-BOW-TF	3		7.0	3	8361621
MC230-03.5A3B-BOW-TF	3.5		7.0	3	8361622
MC230-04.0A3B-BOW-TF	4		8.0	3	8361623
MC230-04.5A3B-BOW-TF	4.5		8.0	3	8361624
MC230-05.0A3B-BOW-TF	5		10.0	3	8361625
MC230-05.5A3B-BOW-TF	5.5		10.0	3	8361626
MC230-06.0A3B-BOW-TF	6		10.0	3	8361627
MC230-06.5A3B-BOW-TF	6.5		13.0	3	8361628
MC230-07.0A3B-BOW-TF	7		13.0	3	8361629
MC230-07.5A3B-BOW-TF	7.5		16.0	3	8361630
MC230-08.0A3B-BOW-TF	8		16.0	3	8361631
MC230-09.0A3B-BOW-TF	9		16.0	3	8361632
MC230-10.0A3B-BOW-TF	10		19.0	3	8361633
MC230-11.0A3B-BOW-TF	11		22.0	3	8361634
MC230-12.0A3B-BOW-TF	12		22.0	3	8361635
MC230-13.0A3B-BOW-TF	13		22.0	3	8361636
MC230-14.0A3B-BOW-TF	14		22.0	3	8361637
MC230-15.0A3B-BOW-TF	15		26.0	3	8361638
MC230-16.0A3B-BOW-TF	16		26.0	3	8361639
MC230-18.0A3B-BOW-TF	18		26.0	3	8361640
MC230-20.0A3B-BOW-TF	20		32.0	3	8361641

Sender

Company

Name

Buildingno./street name

Town/postcode

Date

Signature

Use this form to fax your order now.

In collaboration with:



walter-tools.com

Planned start date is 01.04.2024. Offer validity period: Eight weeks or while stocks last. Please allow three to five working days for delivery. Products on special offer cannot be exchanged. Illustrations show similar products. Subject to change without notice. Recommended sales price.

Solid carbide shoulder/slot milling cutters

MC230 Advance mm

Xill-tec®

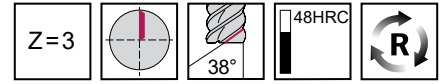
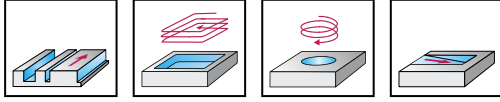

	P	M	K	N	S	H	O
WK40TF	CC	C	C	C	C		

Designation	D _c	R	L _c	Z	SAP No.
MC230-01.0A3BJ-BOW-TF	1		3.0	3	8361642
MC230-01.1A3BJ-BOW-TF	1.1		3.0	3	8361643
MC230-01.2A3BJ-BOW-TF	1.2		3.0	3	8361644
MC230-01.3A3BJ-BOW-TF	1.3		3.0	3	8361645
MC230-01.4A3BJ-BOW-TF	1.4		3.0	3	8361646
MC230-01.5A3BJ-BOW-TF	1.5		3.0	3	8361647
MC230-01.6A3BJ-BOW-TF	1.6		3.0	3	8361648
MC230-01.7A3BJ-BOW-TF	1.7		3.0	3	8361649
MC230-01.8A3BJ-BOW-TF	1.8		3.0	3	8361650
MC230-01.9A3BJ-BOW-TF	1.9		3.0	3	8361651
MC230-02.0A3BJ-BOW-TF	2		3.0	3	8361652
MC230-02.1A3BJ-BOW-TF	2.1		3.0	3	8361653
MC230-02.2A3BJ-BOW-TF	2.2		3.0	3	8361654
MC230-02.3A3BJ-BOW-TF	2.3		3.0	3	8361655
MC230-02.4A3BJ-BOW-TF	2.4		3.0	3	8361656
MC230-02.5A3BJ-BOW-TF	2.5		3.0	3	8361657
MC230-02.6A3BJ-BOW-TF	2.6		3.0	3	8361658
MC230-02.7A3BJ-BOW-TF	2.7		3.0	3	8361659
MC230-02.8A3BJ-BOW-TF	2.8		3.0	3	8361660
MC230-02.9A3BJ-BOW-TF	2.9		3.0	3	8361661
MC230-03.0A3BJ-BOW-TF	3		3.0	3	8361662

Sender

Company

Name

Buildingno./street name

Town/postcode

Date

Signature

Use this form to fax your order now.

In collaboration with:



walter-tools.com

Planned start date is 01.04.2024. Offer validity period: Eight weeks or while stocks last. Please allow three to five working days for delivery. Products on special offer cannot be exchanged. Illustrations show similar products. Subject to change without notice. Recommended sales price.

Solid carbide shoulder/slot milling cutters

MC230 Advance mm

Xill-tec®

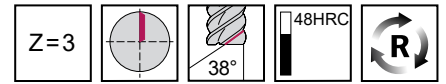
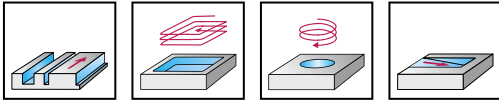

	P	M	K	N	S	H	O
Wk40TF	CC	C	C	C	C		

Designation	D _c	R	L _c	Z	SAP No.
MC230-01.0A3L-BOW-TF	1		4.0	3	8361665
MC230-01.5A3L-BOW-TF	1.5		6.0	3	8361666
MC230-02.0A3L-BOW-TF	2		8.0	3	8361667
MC230-03.0A3L-BOW-TF	3		12.0	3	8361663
MC230-04.0A3L-BOW-TF	4		14.0	3	8361668
MC230-05.0A3L-BOW-TF	5		16.0	3	8361669
MC230-06.0A3L-BOW-TF	6		22.0	3	8361670
MC230-08.0A3L-BOW-TF	8		28.0	3	8361671
MC230-10.0A3L-BOW-TF	10		32.0	3	8361664
MC230-12.0A3L-BOW-TF	12		38.0	3	8361672
MC230-16.0A3L-BOW-TF	16		50.0	3	8361673
MC230-20.0A3L-BOW-TF	20		50.0	3	8361674

Sender

Company

Name

Buildingno./street name

Town/postcode

Date

Signature

Use this form to fax your order now.

In collaboration with:



walter-tools.com

Planned start date is 01.04.2024. Offer validity period: Eight weeks or while stocks last. Please allow three to five working days for delivery. Products on special offer cannot be exchanged. Illustrations show similar products. Subject to change without notice. Recommended sales price.

Solid carbide shoulder/slot milling cutters

MC230 Advance mm

Xill-tec®

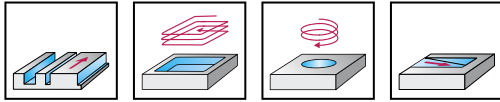

	P	M	K	N	S	H	O
WK40TF	CC	C	C	C	C		

Designation	D _c	R	L _c	Z	SAP No.
MC230-02.0A4S-BOW-TF	2		3.0	4	8361711
MC230-03.0A4S-BOW-TF	3		4.0	4	8361712
MC230-04.0A4S-BOW-TF	4		5.0	4	8361713
MC230-05.0A4S-BOW-TF	5		6.0	4	8361714
MC230-06.0A4S-BOW-TF	6		7.0	4	8361710
MC230-08.0A4S-BOW-TF	8		9.0	4	8361715
MC230-10.0A4S-BOW-TF	10		11.0	4	8361716
MC230-12.0A4S-BOW-TF	12		13.0	4	8361717

Sender

Company

Name

Buildingno./street name

Town/postcode

Date

Signature

Use this form to fax your order now.

In collaboration with:



walter-tools.com

Planned start date is 01.04.2024. Offer validity period: Eight weeks or while stocks last. Please allow three to five working days for delivery. Products on special offer cannot be exchanged. Illustrations show similar products. Subject to change without notice. Recommended sales price.

Solid carbide shoulder/slot milling cutters

MC230 Advance mm

Xill-tec®

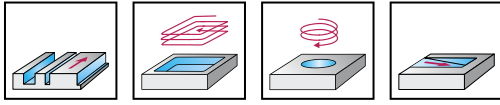

	P	M	K	N	S	H	O
WK40TF	CC	C	C	C	C		

Designation	D _c	R	L _c	Z	SAP No.
MC230-02.0A4A-BOW-TF	2		4.0	4	8361684
MC230-03.0A4A-BOW-TF	3		5.0	4	8361685
MC230-04.0A4A-BOW-TF	4		8.0	4	8361686
MC230-05.0A4A-BOW-TF	5		9.0	4	8361687
MC230-06.0A4A-BOW-TF	6		10.0	4	8361688
MC230-07.0A4A-BOW-TF	7		11.0	4	8361689
MC230-08.0A4A-BOW-TF	8		12.0	4	8361690
MC230-10.0A4A-BOW-TF	10		14.0	4	8361683
MC230-12.0A4A-BOW-TF	12		16.0	4	8361691
MC230-14.0A4A-BOW-TF	14		18.0	4	8361692
MC230-16.0A4A-BOW-TF	16		22.0	4	8361693
MC230-18.0A4A-BOW-TF	18		24.0	4	8361694
MC230-20.0A4A-BOW-TF	20		26.0	4	8361695

Designation	D _c	R	L _c	Z	SAP No.
MC230-02.0W4A-BOW-TF	2		4.0	4	8361746
MC230-03.0W4A-BOW-TF	3		5.0	4	8361747
MC230-04.0W4A-BOW-TF	4		8.0	4	8361748
MC230-05.0W4A-BOW-TF	5		9.0	4	8361749
MC230-06.0W4A-BOW-TF	6		10.0	4	8361750
MC230-08.0W4A-BOW-TF	8		12.0	4	8361751
MC230-10.0W4A-BOW-TF	10		14.0	4	8361752
MC230-12.0W4A-BOW-TF	12		16.0	4	8361753
MC230-14.0W4A-BOW-TF	14		18.0	4	8361754
MC230-16.0W4A-BOW-TF	16		22.0	4	8361755
MC230-20.0W4A-BOW-TF	20		26.0	4	8361756

Sender

Company

Name

Buildingno./street name

Town/postcode

Date

Signature

Use this form to fax your order now.

In collaboration with:



walter-tools.com

Planned start date is 01.04.2024. Offer validity period: Eight weeks or while stocks last. Please allow three to five working days for delivery. Products on special offer cannot be exchanged. Illustrations show similar products. Subject to change without notice. Recommended sales price.

Solid carbide shoulder/slot milling cutters

MC230 Advance mm

Xill-tec®



- Long reach

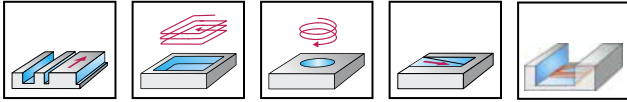

	P	M	K	N	S	H	O
WK40TF	CC	C	C	C	C		

Designation	D _c	R	L _c	Z	SAP No.
MC230-02.0A4BC-BOW-TF	2		7.0	4	8194760
MC230-02.5A4BC-BOW-TF	2.5		8.0	4	8194761
MC230-03.0A4BC-BOW-TF	3		8.0	4	8194762
MC230-03.5A4BC-BOW-TF	3.5		10.0	4	8194763
MC230-04.0A4BC-BOW-TF	4		11.0	4	8194764
MC230-04.5A4BC-BOW-TF	4.5		11.0	4	8194765
MC230-05.0A4BC-BOW-TF	5		13.0	4	8194766
MC230-05.5A4BC-BOW-TF	5.5		13.0	4	8194767
MC230-06.0A4BC-BOW-TF	6		13.0	4	8194768
MC230-06.5A4BC-BOW-TF	6.5		16.0	4	8194769
MC230-07.0A4BC-BOW-TF	7		16.0	4	8194770
MC230-08.0A4BC-BOW-TF	8		19.0	4	8194771
MC230-09.0A4BC-BOW-TF	9		19.0	4	8194772
MC230-10.0A4BC-BOW-TF	10		22.0	4	8194773
MC230-12.0A4BC-BOW-TF	12		26.0	4	8194774
MC230-14.0A4BC-BOW-TF	14		26.0	4	8194775
MC230-16.0A4BC-BOW-TF	16		32.0	4	8194776
MC230-18.0A4BC-BOW-TF	18		32.0	4	8194777
MC230-20.0A4BC-BOW-TF	20		38.0	4	8194778

Designation	D _c	R	L _c	Z	SAP No.
MC230-02.0W4BC-BOW-TF	2		7.0	4	8194818
MC230-02.5W4BC-BOW-TF	2.5		8.0	4	8194819
MC230-03.0W4BC-BOW-TF	3		8.0	4	8194820
MC230-04.0W4BC-BOW-TF	4		11.0	4	8194821
MC230-05.0W4BC-BOW-TF	5		13.0	4	8194822
MC230-06.0W4BC-BOW-TF	6		13.0	4	8194823
MC230-07.0W4BC-BOW-TF	7		16.0	4	8194824
MC230-08.0W4BC-BOW-TF	8		19.0	4	8194825
MC230-09.0W4BC-BOW-TF	9		19.0	4	8194826
MC230-10.0W4BC-BOW-TF	10		22.0	4	8194827
MC230-12.0W4BC-BOW-TF	12		26.0	4	8194828
MC230-14.0W4BC-BOW-TF	14		26.0	4	8194829
MC230-16.0W4BC-BOW-TF	16		32.0	4	8194830
MC230-18.0W4BC-BOW-TF	18		32.0	4	8194831
MC230-20.0W4BC-BOW-TF	20		38.0	4	8194832
MC230-25.0W4BC-BOW-TF	25		45.0	4	8194833

Sender

Company

Name

Buildingno./street name

Town/postcode

Date

Signature

Use this form to fax your order now.

In collaboration with:



walter-tools.com

Planned start date is 01.04.2024. Offer validity period: Eight weeks or while stocks last. Please allow three to five working days for delivery. Products on special offer cannot be exchanged. Illustrations show similar products. Subject to change without notice. Recommended sales price.

Solid carbide shoulder/slot milling cutters

MC230 Advance mm

Xill-tec®



- Long reach

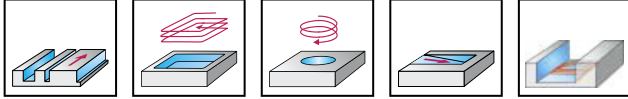

Designation	D _c	R	L _c	Z	SAP No.
MC230-06.0A4LC-BOW-TF	6		13.0	4	8361793
MC230-08.0A4LC-BOW-TF	8		19.0	4	8361794
MC230-10.0A4LC-BOW-TF	10		22.0	4	8361795
MC230-12.0A4LC-BOW-TF	12		26.0	4	8361796
MC230-16.0A4LC-BOW-TF	16		32.0	4	8361797
MC230-20.0A4LC-BOW-TF	20		38.0	4	8361798

Designation	D _c	R	L _c	Z	SAP No.
MC230-06.0W4LC-BOW-TF	6		13.0	4	8361799
MC230-08.0W4LC-BOW-TF	8		19.0	4	8361800
MC230-10.0W4LC-BOW-TF	10		22.0	4	8361801
MC230-12.0W4LC-BOW-TF	12		26.0	4	8361802
MC230-16.0W4LC-BOW-TF	16		32.0	4	8361803
MC230-20.0W4LC-BOW-TF	20		38.0	4	8361804

Sender

Company

Name

Buildingno./street name

Town/postcode

Date

Signature

Use this form to fax your order now.

In collaboration with:



walter-tools.com

Planned start date is 01.04.2024. Offer validity period: Eight weeks or while stocks last. Please allow three to five working days for delivery. Products on special offer cannot be exchanged. Illustrations show similar products. Subject to change without notice. Recommended sales price.

Solid carbide shoulder/slot milling cutters

MC230 Advance mm



Xill-tec®

- Long reach

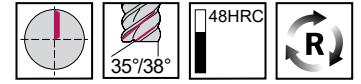
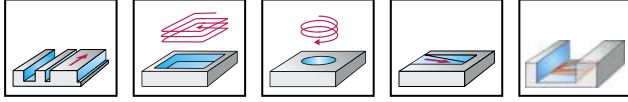

	P	M	K	N	S	H	O
WK40TF	CC	C	C	C	C		

Designation	D _c	R	L _c	Z	SAP No.
MC230-02.0A4B020C-BOW-TF	2	0.2	7.0	4	8194779
MC230-03.0A4B030C-BOW-TF	3	0.3	8.0	4	8194780
MC230-03.0A4B050C-BOW-TF	3	0.5	8.0	4	8194781
MC230-04.0A4B020C-BOW-TF	4	0.2	11.0	4	8194782
MC230-04.0A4B050C-BOW-TF	4	0.5	11.0	4	8194783
MC230-05.0A4B050C-BOW-TF	5	0.5	13.0	4	8194784
MC230-05.0A4B100C-BOW-TF	5	1	13.0	4	8194785
MC230-06.0A4B050C-BOW-TF	6	0.5	13.0	4	8194786
MC230-06.0A4B080C-BOW-TF	6	0.8	13.0	4	8194787
MC230-06.0A4B100C-BOW-TF	6	1	13.0	4	8194788
MC230-08.0A4B050C-BOW-TF	8	0.5	19.0	4	8194789
MC230-08.0A4B080C-BOW-TF	8	0.8	19.0	4	8194790
MC230-08.0A4B100C-BOW-TF	8	1	19.0	4	8194791
MC230-08.0A4B150C-BOW-TF	8	1.5	19.0	4	8194792
MC230-08.0A4B200C-BOW-TF	8	2	19.0	4	8194793
MC230-10.0A4B050C-BOW-TF	10	0.5	22.0	4	8194794
MC230-10.0A4B080C-BOW-TF	10	0.8	22.0	4	8194795
MC230-10.0A4B100C-BOW-TF	10	1	22.0	4	8194796
MC230-10.0A4B150C-BOW-TF	10	1.5	22.0	4	8194797
MC230-10.0A4B200C-BOW-TF	10	2	22.0	4	8194798
MC230-12.0A4B050C-BOW-TF	12	0.5	26.0	4	8194799
MC230-12.0A4B080C-BOW-TF	12	0.8	26.0	4	8194800
MC230-12.0A4B100C-BOW-TF	12	1	26.0	4	8194801
MC230-12.0A4B150C-BOW-TF	12	1.5	26.0	4	8194802
MC230-12.0A4B200C-BOW-TF	12	2	26.0	4	8194803
MC230-12.0A4B250C-BOW-TF	12	2.5	26.0	4	8194804
MC230-12.0A4B300C-BOW-TF	12	3	26.0	4	8194805
MC230-16.0A4B050C-BOW-TF	16	0.5	32.0	4	8194806

Designation	D _c	R	L _c	Z	SAP No.
MC230-16.0A4B100C-BOW-TF	16	1	32.0	4	8194807
MC230-16.0A4B200C-BOW-TF	16	2	32.0	4	8194808
MC230-16.0A4B250C-BOW-TF	16	2.5	32.0	4	8194809
MC230-16.0A4B300C-BOW-TF	16	3	32.0	4	8194810
MC230-16.0A4B400C-BOW-TF	16	4	32.0	4	8194811
MC230-20.0A4B050C-BOW-TF	20	0.5	38.0	4	8194812
MC230-20.0A4B100C-BOW-TF	20	1	38.0	4	8194813
MC230-20.0A4B200C-BOW-TF	20	2	38.0	4	8194814
MC230-20.0A4B250C-BOW-TF	20	2.5	38.0	4	8194815
MC230-20.0A4B300C-BOW-TF	20	3	38.0	4	8194816
MC230-20.0A4B400C-BOW-TF	20	4	38.0	4	8194817

Sender

Company

Name

Buildingno./street name

Town/postcode

Date

Signature

Use this form to fax your order now.

In collaboration with:



walter-tools.com

Planned start date is 01.04.2024. Offer validity period: Eight weeks or while stocks last. Please allow three to five working days for delivery. Products on special offer cannot be exchanged. Illustrations show similar products. Subject to change without notice. Recommended sales price.

Solid carbide shoulder/slot milling cutters

MC230 Advance mm

Xill-tec®



- Long reach

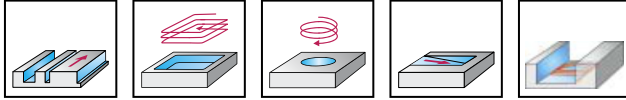

	P	M	K	N	S	H	O
WK40TF	CC	C	C	C	C		

Designation	D _c	R	L _c	Z	SAP No.
MC230-05.0W4B050C-BOW-TF	5	0.5	13.0	4	8194834
MC230-06.0W4B050C-BOW-TF	6	0.5	13.0	4	8194835
MC230-06.0W4B080C-BOW-TF	6	0.8	13.0	4	8194836
MC230-06.0W4B100C-BOW-TF	6	1	13.0	4	8194837
MC230-08.0W4B050C-BOW-TF	8	0.5	19.0	4	8194838
MC230-08.0W4B080C-BOW-TF	8	0.8	19.0	4	8194839
MC230-08.0W4B100C-BOW-TF	8	1	19.0	4	8194840
MC230-08.0W4B150C-BOW-TF	8	1.5	19.0	4	8194841
MC230-08.0W4B200C-BOW-TF	8	2	19.0	4	8194842
MC230-10.0W4B050C-BOW-TF	10	0.5	22.0	4	8194843
MC230-10.0W4B080C-BOW-TF	10	0.8	22.0	4	8194844
MC230-10.0W4B100C-BOW-TF	10	1	22.0	4	8194845
MC230-10.0W4B150C-BOW-TF	10	1.5	22.0	4	8194846
MC230-10.0W4B200C-BOW-TF	10	2	22.0	4	8194847
MC230-12.0W4B050C-BOW-TF	12	0.5	26.0	4	8194848
MC230-12.0W4B080C-BOW-TF	12	0.8	26.0	4	8194849
MC230-12.0W4B100C-BOW-TF	12	1	26.0	4	8194850
MC230-12.0W4B150C-BOW-TF	12	1.5	26.0	4	8194851
MC230-12.0W4B200C-BOW-TF	12	2	26.0	4	8194852
MC230-12.0W4B250C-BOW-TF	12	2.5	26.0	4	8194853
MC230-12.0W4B300C-BOW-TF	12	3	26.0	4	8194854
MC230-16.0W4B050C-BOW-TF	16	0.5	32.0	4	8194855
MC230-16.0W4B100C-BOW-TF	16	1	32.0	4	8194856
MC230-16.0W4B200C-BOW-TF	16	2	32.0	4	8194857
MC230-16.0W4B250C-BOW-TF	16	2.5	32.0	4	8194858
MC230-16.0W4B300C-BOW-TF	16	3	32.0	4	8194859
MC230-16.0W4B400C-BOW-TF	16	4	32.0	4	8194860
MC230-20.0W4B050C-BOW-TF	20	0.5	38.0	4	8194861

Designation	D _c	R	L _c	Z	SAP No.
MC230-20.0W4B100C-BOW-TF	20	1	38.0	4	8194862
MC230-20.0W4B200C-BOW-TF	20	2	38.0	4	8194863
MC230-20.0W4B250C-BOW-TF	20	2.5	38.0	4	8194864
MC230-20.0W4B300C-BOW-TF	20	3	38.0	4	8194865
MC230-20.0W4B400C-BOW-TF	20	4	38.0	4	8194866
MC230-25.0W4B100C-BOW-TF	25	1	45.0	4	8194867
MC230-25.0W4B200C-BOW-TF	25	2	45.0	4	8194868
MC230-25.0W4B300C-BOW-TF	25	3	45.0	4	8194869
MC230-25.0W4B400C-BOW-TF	25	4	45.0	4	8194870

Sender

Company

Name

Buildingno./street name

Town/postcode

Date

Signature

Use this form to fax your order now.

In collaboration with:



walter-tools.com

Planned start date is 01.04.2024. Offer validity period: Eight weeks or while stocks last. Please allow three to five working days for delivery. Products on special offer cannot be exchanged. Illustrations show similar products. Subject to change without notice. Recommended sales price.

Solid carbide shoulder/slot milling cutters

MC230 Advance mm

Xill-tec®

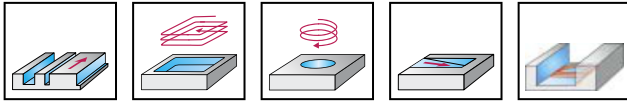

	P	M	K	N	S	H	O
WK40TF	CC	C	C	C	C		

Designation	D _c	R	L _c	Z	SAP No.
MC230-06.0A4L050C-BOW-TF	6	0.5	13.0	4	8361805
MC230-06.0A4L100C-BOW-TF	6	1	13.0	4	8361806
MC230-08.0A4L050C-BOW-TF	8	0.5	19.0	4	8361807
MC230-08.0A4L100C-BOW-TF	8	1	19.0	4	8361808
MC230-08.0A4L200C-BOW-TF	8	2	19.0	4	8361809
MC230-10.0A4L050C-BOW-TF	10	0.5	22.0	4	8361810
MC230-10.0A4L100C-BOW-TF	10	1	22.0	4	8361811
MC230-10.0A4L200C-BOW-TF	10	2	22.0	4	8361812
MC230-12.0A4L050C-BOW-TF	12	0.5	26.0	4	8361813
MC230-12.0A4L100C-BOW-TF	12	1	26.0	4	8361814
MC230-12.0A4L200C-BOW-TF	12	2	26.0	4	8361815
MC230-12.0A4L300C-BOW-TF	12	3	26.0	4	8361816
MC230-16.0A4L100C-BOW-TF	16	1	32.0	4	8361817
MC230-16.0A4L200C-BOW-TF	16	2	32.0	4	8361818
MC230-16.0A4L400C-BOW-TF	16	4	32.0	4	8361819
MC230-20.0A4L100C-BOW-TF	20	1	38.0	4	8361820
MC230-20.0A4L200C-BOW-TF	20	2	38.0	4	8361821
MC230-20.0A4L400C-BOW-TF	20	4	38.0	4	8361822

Sender

Company

Name

Buildingno./street name

Town/postcode

Date

Signature

Use this form to fax your order now.

In collaboration with:



walter-tools.com

Planned start date is 01.04.2024. Offer validity period: Eight weeks or while stocks last. Please allow three to five working days for delivery. Products on special offer cannot be exchanged. Illustrations show similar products. Subject to change without notice. Recommended sales price.

Solid carbide shoulder/slot milling cutters

MC230 Advance mm

Xill-tec®

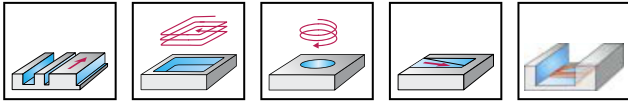

	P	M	K	N	S	H	O
WK40TF	CC	C	C	C	C		

Designation	D _c	R	L _c	Z	SAP No.
MC230-06.0W5B-BOW-TF	6		13.0	5	8361757
MC230-08.0W5B-BOW-TF	8		19.0	5	8361758
MC230-10.0W5B-BOW-TF	10		22.0	5	8361759
MC230-12.0W5B-BOW-TF	12		26.0	5	8361760
MC230-16.0W5B-BOW-TF	16		32.0	5	8361761
MC230-20.0W5B-BOW-TF	20		38.0	5	8361762

Sender

Company

Name

Buildingno./street name

Town/postcode

Date

Signature

Use this form to fax your order now.

In collaboration with:



walter-tools.com

Planned start date is 01.04.2024. Offer validity period: Eight weeks or while stocks last. Please allow three to five working days for delivery. Products on special offer cannot be exchanged. Illustrations show similar products. Subject to change without notice. Recommended sales price.

Solid carbide shoulder/slot milling cutters

MC230 Advance mm

Xill-tec®

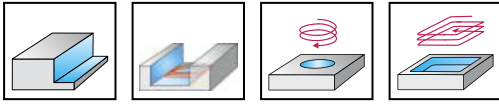

	P	M	K	N	S	H	O
WK40TF	CC	C	C	C	C		

Designation	D _c	R	L _c	Z	SAP No.
MC230-06.0W5L-BOW-TF	6		22.0	5	8361763
MC230-08.0W5L-BOW-TF	8		28.0	5	8361765
MC230-10.0W5L-BOW-TF	10		32.0	5	8361766
MC230-12.0W5L-BOW-TF	12		40.0	5	8361764

Sender

Company

Name

Buildingno./street name

Town/postcode

Date

Signature

Use this form to fax your order now.

In collaboration with:



walter-tools.com

Planned start date is 01.04.2024. Offer validity period: Eight weeks or while stocks last. Please allow three to five working days for delivery. Products on special offer cannot be exchanged. Illustrations show similar products. Subject to change without notice. Recommended sales price.

Solid carbide shoulder/slot milling cutters

MC230 Advance mm

Xill-tec®

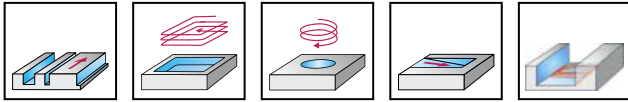

	P	M	K	N	S	H	O
WK40TF	CC	C	C	C	C		

Designation	D _c	R	L _c	Z	SAP No.
MC230-06.0A4L-BOW-TF	6		22.0	4	8361698
MC230-08.0A4L-BOW-TF	8		28.0	4	8361699
MC230-10.0A4L-BOW-TF	10		32.0	4	8361696
MC230-12.0A4L-BOW-TF	12		40.0	4	8361700
MC230-14.0A4L-BOW-TF	14		50.0	4	8361701
MC230-16.0A5L-BOW-TF	16		50.0	5	8361702
MC230-20.0A5L-BOW-TF	20		55.0	5	8361703
MC230-20.0A6LJ-BOW-TF	20		75.0	6	8361718
MC230-25.0A8LJ-BOW-TF	25		90.0	8	8361719

Designation	D _c	R	L _c	Z	SAP No.
MC230-06.0W4L-BOW-TF	6		22.0	4	8361704
MC230-08.0W4L-BOW-TF	8		28.0	4	8361705
MC230-10.0W4L-BOW-TF	10		32.0	4	8361706
MC230-12.0W4L-BOW-TF	12		40.0	4	8361707
MC230-14.0W4L-BOW-TF	14		50.0	4	8361708
MC230-16.0W5L-BOW-TF	16		50.0	5	8361697
MC230-20.0W5L-BOW-TF	20		55.0	5	8361709
MC230-20.0W6LJ-BOW-TF	20		75.0	6	8361767
MC230-25.0W8LJ-BOW-TF	25		90.0	8	8361768

Sender

Company

Name

Buildingno./street name

Town/postcode

Date

Signature

Use this form to fax your order now.

In collaboration with:



walter-tools.com

Planned start date is 01.04.2024. Offer validity period: Eight weeks or while stocks last. Please allow three to five working days for delivery. Products on special offer cannot be exchanged. Illustrations show similar products. Subject to change without notice. Recommended sales price.

Solid carbide shoulder/slot milling cutters

MC230 Advance mm

Xill-tec®

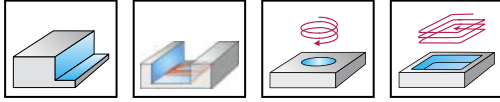

	P	M	K	N	S	H	O
WK40TF	CC	C	C	C	C		

Designation	D _c	R	L _c	Z	SAP No.
MC230-06.0A4XL-BOW-TF	6		30.0	4	8361722
MC230-08.0A4XL-BOW-TF	8		40.0	4	8361723
MC230-10.0A4XL-BOW-TF	10		50.0	4	8361724
MC230-12.0A4XL-BOW-TF	12		60.0	4	8361725
MC230-16.0A5XK-BOW-TF	16		65.0	5	8361720
MC230-16.0A5XL-BOW-TF	16		80.0	5	8361721
MC230-20.0A6XL-BOW-TF	20		100.0	6	8361726
MC230-25.0A8XL-BOW-TF	25		125.0	8	8361727

Designation	D _c	R	L _c	Z	SAP No.
MC230-04.0W4XL-BOW-TF	4		20.0	4	8361772
MC230-05.0W4XL-BOW-TF	5		25.0	4	8361773
MC230-06.0W4XL-BOW-TF	6		30.0	4	8361774
MC230-08.0W4XL-BOW-TF	8		40.0	4	8361775
MC230-10.0W4XL-BOW-TF	10		50.0	4	8361770
MC230-12.0W4XL-BOW-TF	12		60.0	4	8361776
MC230-14.0W4XL-BOW-TF	14		70.0	4	8361777
MC230-16.0W5XK-BOW-TF	16		65.0	5	8361769
MC230-16.0W5XL-BOW-TF	16		80.0	5	8361778
MC230-18.0W5XL-BOW-TF	18		90.0	5	8361779
MC230-20.0W6XL-BOW-TF	20		100.0	6	8361771
MC230-25.0W8XL-BOW-TF	25		125.0	8	8361780

Sender

Company

Name

Buildingno./street name

Town/postcode

Date

Signature

Use this form to fax your order now.

In collaboration with:



walter-tools.com

Planned start date is 01.04.2024. Offer validity period: Eight weeks or while stocks last. Please allow three to five working days for delivery. Products on special offer cannot be exchanged. Illustrations show similar products. Subject to change without notice. Recommended sales price.

Solid carbide shoulder/slot milling cutters

MC233 Advance mm

Xill-tec®



- Chipbreaker

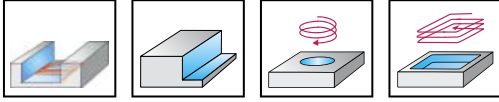

	P	M	K	N	S	H	O
WK40TF	CC	C	C	C	C		

Designation	D _c	R	L _c	Z	SAP No.
MC233-08.0W4L-BOW-TF	8		28.0	4	8361781
MC233-10.0W4L-BOW-TF	10		32.0	4	8361782
MC233-12.0W4L-BOW-TF	12		40.0	4	8361783
MC233-16.0W5L-BOW-TF	16		50.0	5	8361784
MC233-20.0W5L-BOW-TF	20		55.0	5	8361785
MC233-25.0W8LJ-BOW-TF	25		90.0	8	8361786

Designation	D _c	R	L _c	Z	SAP No.
MC233-08.0W4XL-BOW-TF	8		40.0	4	8361787
MC233-10.0W4XL-BOW-TF	10		50.0	4	8361789
MC233-12.0W4XL-BOW-TF	12		60.0	4	8361790
MC233-16.0W5XL-BOW-TF	16		80.0	5	8361791
MC233-20.0W6XL-BOW-TF	20		100.0	6	8361792
MC233-25.0W8XL-BOW-TF	25		125.0	8	8361788

Sender

Company

Name

Buildingno./street name

Town/postcode

Date

Signature

Use this form to fax your order now.

In collaboration with:



walter-tools.com

Planned start date is 01.04.2024. Offer validity period: Eight weeks or while stocks last. Please allow three to five working days for delivery. Products on special offer cannot be exchanged. Illustrations show similar products. Subject to change without notice. Recommended sales price.

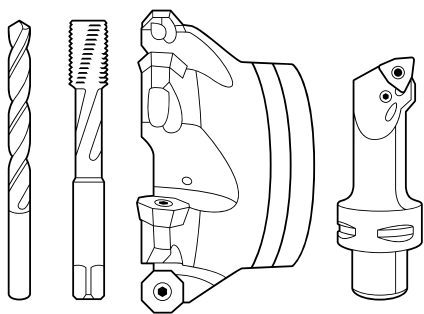

www.walter-tools.com

BARNSTEENSTRAAT 1

7554 TC HENGELO

0031 (74) 2558282

gereedschappen@leering.nl

